



# Jackhammer Trolley JHT-U-2



**OPERATOR'S MANUAL**

# TABLE OF CONTENTS

---

INTRODUCTION.....	1
DISCLAIMER .....	1
ABOUT THIS MANUAL.....	2
SAFETY INFORMATION.....	3
SAFETY DECAL.....	4
PRODUCT DESCRIPTION AND SPECIFICATION .....	5
INSTRUCTIONS FOR USE.....	5
FITTING A JACKHAMMER .....	5
BRAKE LEVER ADJUSTMENTS.....	8
USING THE JHT-U-2 .....	9
SERVICING THE JACKHAMMER TROLLEY.....	9
LIMITED WARRANTY .....	10
WARRANTY EXCLUSIONS.....	11
OWNER’S RESPONSIBILITY UNDER THIS LIMITED WARRANTY.....	11
CONTACT INFORMATION .....	12
APPENDICES.....	13
APPENDIX A – UNIVERSAL BLOCK SET BREAKDOWN .....	13
APPENDIX B – JHT-U-2 RISK ASSESSMENT .....	14

# INTRODUCTION

---

Thank you for purchasing a MAKINEX product.

This manual provides information and procedures to safely operate and maintain the **JHT-U-2** Jack Hammer Trolley. For your own safety and protection from injury, carefully read, understand, and observe the safety instructions described in this manual.

Keep this manual or a copy of it with the machine. If you lose this manual or need an additional copy, please contact MAKINEX. This machine is designed and built with user safety in mind; however, it can present hazards if improperly operated and serviced. If there are any questions regarding operating or servicing of this machine, please contact MAKINEX.

All rights, especially copying and distribution rights are reserved.

Copyright 2019 by MAKINEX.

No part of this publication may be reproduced in any form or by any means, electronic or mechanical, including photocopying, without express written permission from MAKINEX.

Any type of reproduction or distribution not authorised by MAKINEX represents an infringement of valid copyrights and will be prosecuted. We expressly reserve the right to make technical modifications, even without due notice, which aim at improving our machines or their safety standards.

## DISCLAIMER

---

MAKINEX and its affiliates take no responsibility for any damage, injury or death resulting from the incorrect or unsafe use of this product. Use of this product should be undertaken by competent persons only. It is the operator's responsibility to ensure that the following safety procedures are followed. If you are unsure, do not operate this product.

Record the model and serial numbers as well as date and place of purchase for future reference. Have this information available when ordering parts and when making technical or warranty inquiries.

**MAKINEX SUPPORT**

**Refer to contact details on pg. 12**

**MODEL NO.**

**JHT-U-2**

**SERIAL NO.**

**DATE OF PURCHASE**

**PURCHASE LOCATION**

# ABOUT THIS MANUAL

---

This manual is designed to provide the user with the information required to operate and maintain the Jackhammer Trolley correctly and safely.

This manual uses the following symbols to help differentiate between different kinds of information. The safety symbol is used with a key word to alert you to potential hazards in operating and owning power equipment. Follow all safety messages to avoid or reduce the risk of serious injury or death.

## KEY TERMS



**READ CAREFULLY** – refers to **important information** that should be paid careful attention.



**CAUTION** - indicates a situation that **may** cause injury or damage to the machine if the user does not follow the instructions.



**WARNING** – indicates a situation that **may** cause injury or death if the user does not follow the instructions correctly.



**DANGER** – indicates a situation that **will** cause injury or death if the user does not follow the instructions as written.



**PROHIBITED** – identifies actions that **should never** be carried out by any one interacting with the machine.

These safety warnings do not eliminate all possible hazards that could occur therefore it is essential to use common sense and to strictly follow any instructions to prevent accidents.

## SAFETY INFORMATION

Throughout this document there are several safety warnings. The user should read through this complete document before using the Jackhammer Trolley.



**READ  
CAREFULLY**

Ensure you read all information contained in this manual before using the Jackhammer Trolley.



**READ  
CAREFULLY**

Read all safety and instructional stickers displayed on each component of the Jackhammer Trolley.



**READ  
CAREFULLY**

Ensure you read the manual and safety instructions for the Jackhammer and other components that are part of this unit. See Appendix for more information.



**PROHIBITED**

It is forbidden to remove any safety or instructional stickers or panels from the Jackhammer Trolley.



**DANGER**

Always wear the recommended personal protective equipment.



**PROHIBITED**

Never expose the machine to moisture or rain.

## PROPOSITION 65 WARNINGS



**WARNING**

This product contains Lead, a chemical known to the State of California to cause birth defects or other reproductive harm.



**WARNING**

This product contains one or more chemicals known to the State of California to cause birth defects or other reproductive harm.



**WARNING**

Exhaust gases from this product contain chemicals known to State of California to cause cancer, birth defects or other reproductive harm.

**WASH HANDS AFTER HANDLING THIS PRODUCT**

## SAFETY DECAL

There is a safety and information panel provided on the front of the Jackhammer Trolley to alert the user of potential safety risks/hazards. Please read and adhere to all instructions on the Unit.

**MAKINEX**  
**CONSTRUCTION PRODUCTS**  
**Jackhammer Trolley-JHT**

**SAFETY OPERATING INSTRUCTIONS**

- Ensure jackhammer is switched off before plugging in or disconnecting from mains power
- Use a dedicated mains power supply with extension lead not exceeding 10 metres/ 11 yards
- Use caution when changing attachments
- Take regular breaks to avoid personal injury, stress, strain and fatigue

[makinex.com](http://makinex.com)

Designed in Australia | Made in China  
US Patent No.s D668420 & 8240682

Icons: Safety glasses, Face mask, Ear protection, Safety boots, Weight (28kg / 61.7 lb), Extension lead (10m / 11 yd MAX), Manual, Hand holding tool.

⚠ This product can expose you to chemicals including Lead, which is known to the State of California to cause cancer and birth defects or other reproductive harm. For more information go to [www.P65Warnings.ca.gov](http://www.P65Warnings.ca.gov)

## PRODUCT DESCRIPTION AND SPECIFICATION

The Jackhammer Trolley enables your demolition hammer to lift most types of Ceramic Floor Tiles, Vinyl and Cork with less effort.

With a wide range of angle, the Jackhammer Trolley adapts to any situation with a maximum leverage.

### Features

- Durable zinc coated frame
- Easy Angle adjustment
- Will suit most 16kg (35lbs) hammers
- Anti-vibration ergonomic design
- Large wheels

<b>HEIGHT WHEN RAISED</b>	1100mm/43.3"
<b>HEIGHT WHEN LOWERED</b>	600mm/23.6"
<b>OVERALL WIDTH</b>	510mm/20"
<b>OVERALL LENGTH</b>	1100mm/43.3"
<b>ANGLE OF ADJUSTMENT</b>	73° (93° closed, 20° open)
<b>WEIGHT (WITHOUT JACKHAMMER)</b>	28kg/62lb

## INSTRUCTIONS FOR USE



Do not operate the Jackhammer without wearing the appropriate personal protective equipment and assessing the surrounding area for hazards.

## FITTING A JACKHAMMER

### Tools Required

- 17mm spanner



- 19mm spanner



- 2mm allen key



- Pliers





## PRODUCT BREAKDOWN

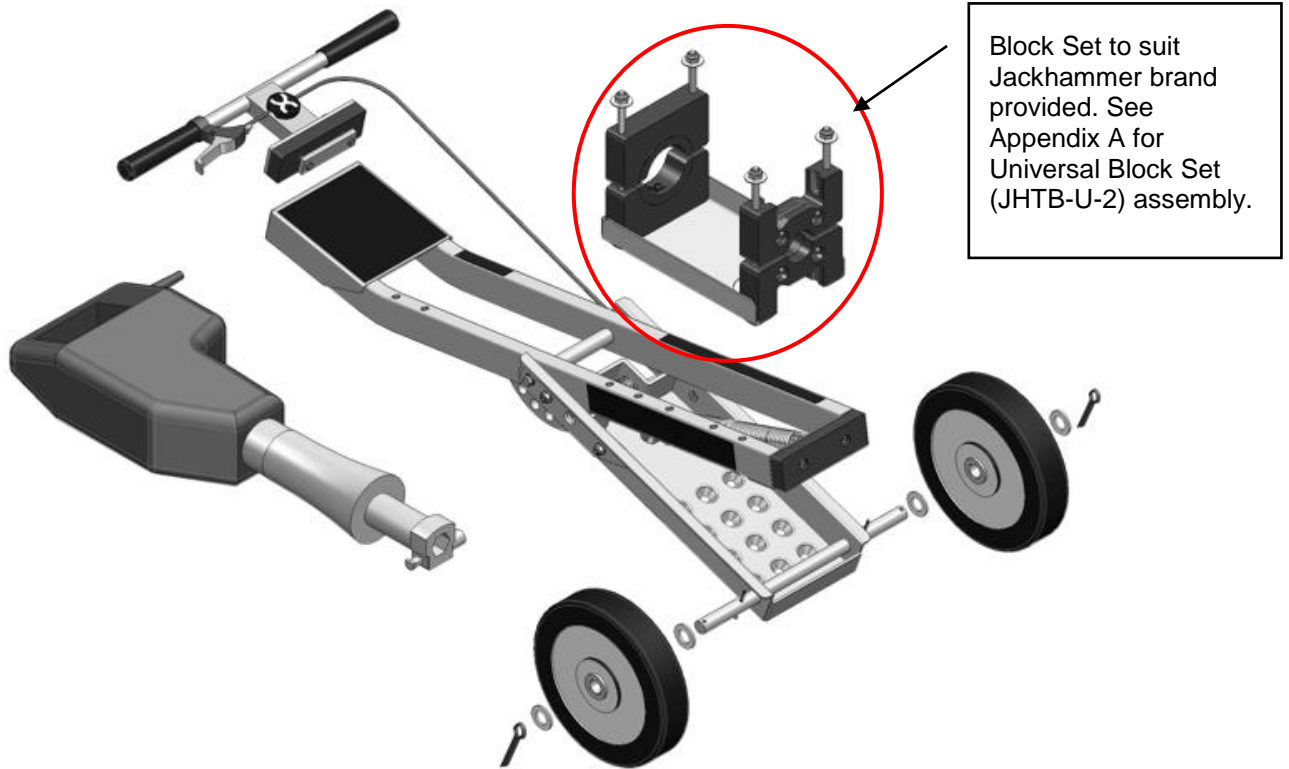

Jackhammer sold separately

### Step 1:

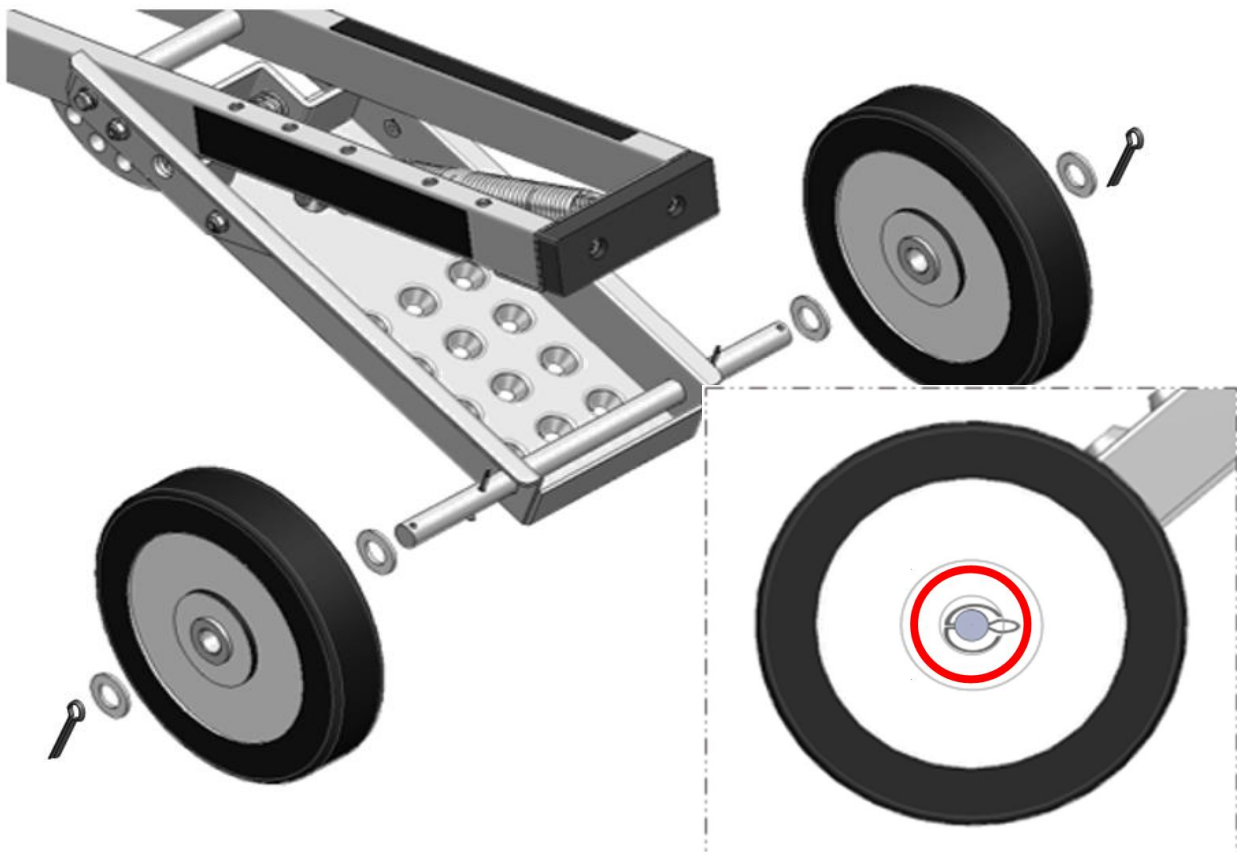



**Step 2:**

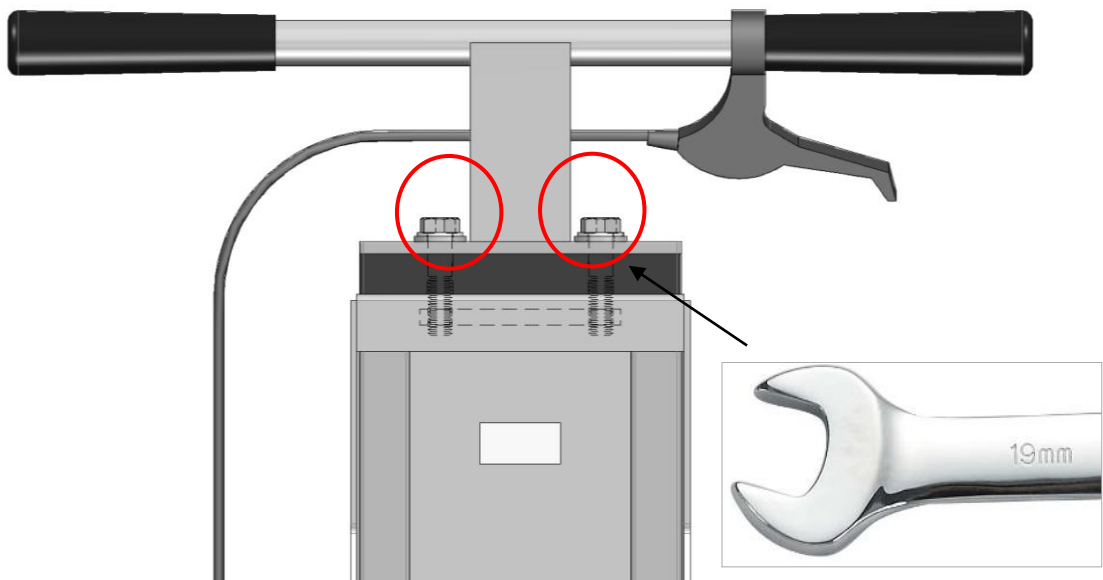

**Step 3:**

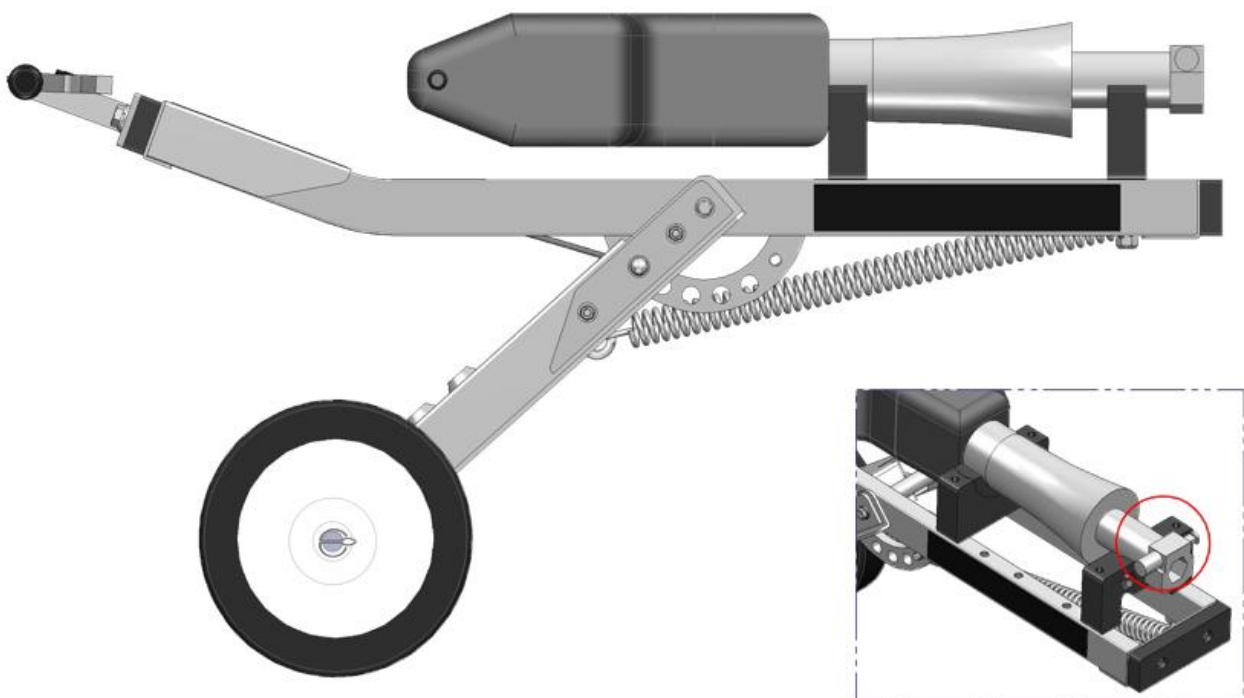

## Step 4:

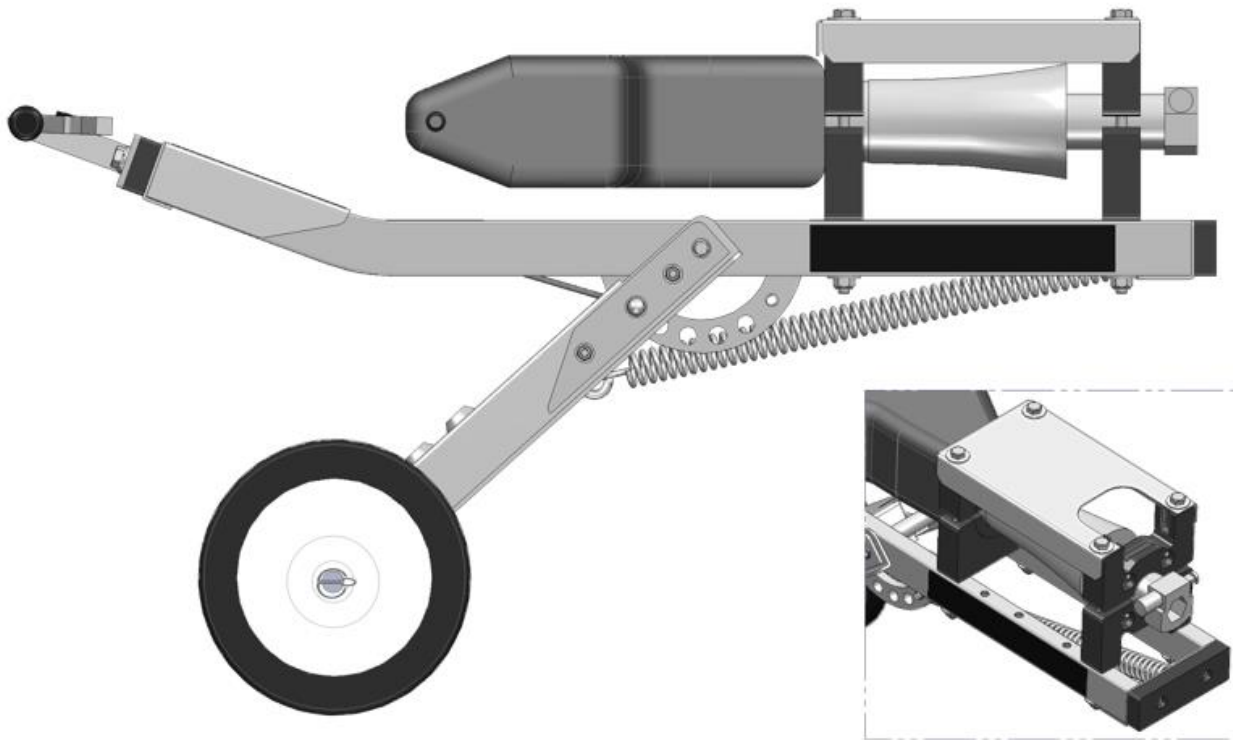

## BRAKE LEVER ADJUSTMENTS

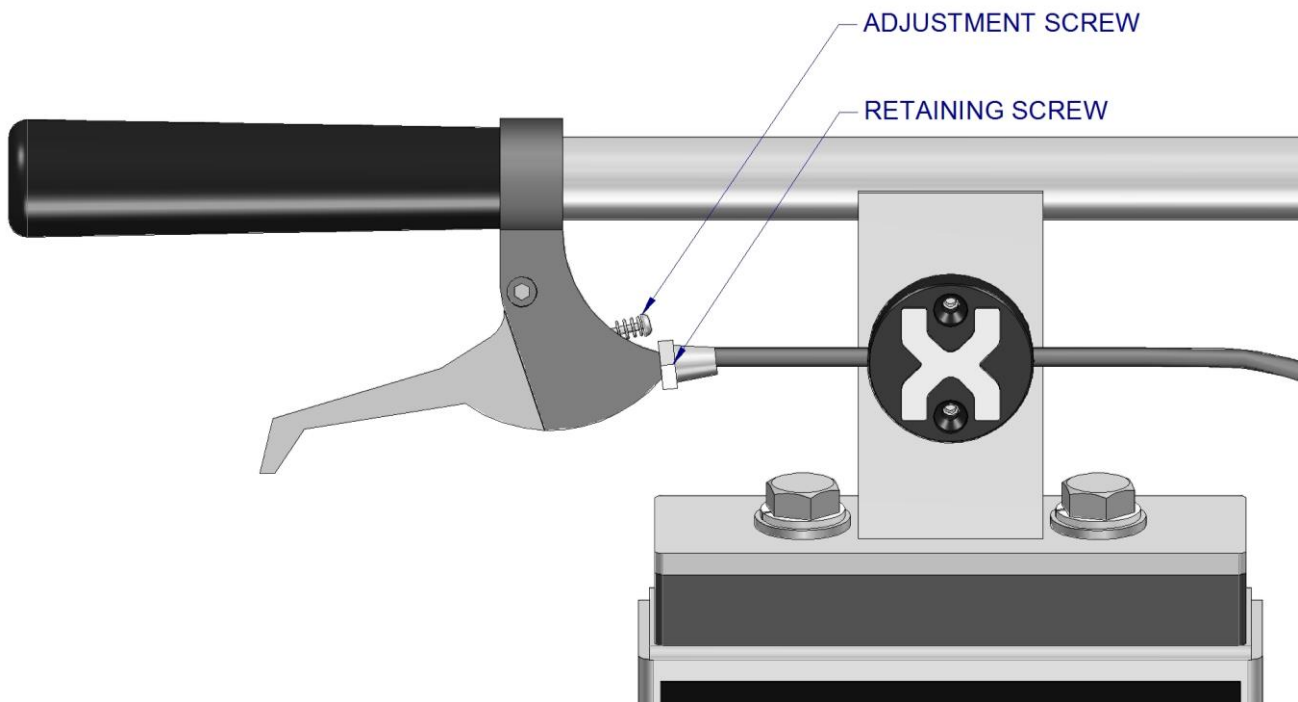

1. Ensure cable is not kinked anywhere along its length.
2. Tighten retaining screw with pliers.
3. Tighten adjustment screw with 2mm allen key to remove slack from the cable.

**NOTE:** Some slack in the mechanism is normal.

## USING THE JHT-U-2

---



Ensure the machine is switched OFF before plugging in.



Ensure Chisel or Tile Smasher is correctly inserted and locked in position before use.

1. Ensure Hammer/Breaker is secure and cannot rotate.
2. Guide the Hammer/Breaker cable through the cable holder on the handle.
3. Position and angle before commencing work.

### To change the angle:

- a. Lift the handles to take the weight off lock mechanism.
- b. Pull the brake lever to disengage the lock mechanism.
- c. Lift/ lower the height of the handle to desired angle.
- d. Release brake lever to re-engage the lock mechanism.

4. Switch on Hammer/Breaker with trigger
5. Refer to Hammer/Breaker Instruction Manual for more detail on operation and service



Never allow Hammer/Breaker ormoil to overheat.



Always switch off machine before unplugging.

## SERVICING THE JACKHAMMER TROLLEY

---

### Every Use:

- Inspect frame for damage.
- Ensure bolts are secure.

### Every 3 Months:

- Adjust brake lever to eliminate free-play.
- Lubricate brake lever cable.
  - Drip light weight oil from the top of the cable so it runs through the cable housing.
- Grease the pivot axle.

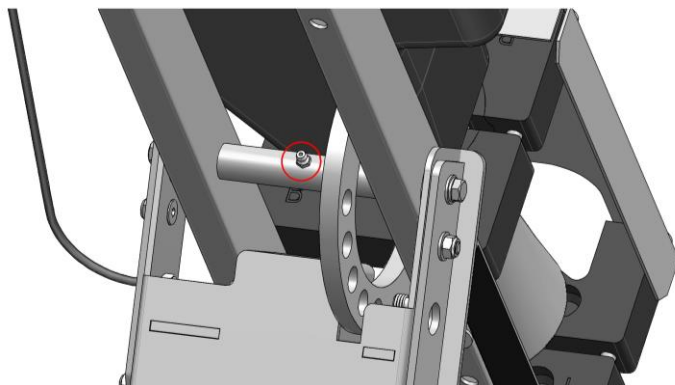

## LIMITED WARRANTY

---

To take advantage of the MAKINEX limited warranty, you must have maintenance performed by an authorised MAKINEX dealer or MAKINEX service technician. You are free to have your MAKINEX product serviced by any suitably qualified persons and this will not affect your statutory warranties, however, failure by the owner to have the recommended servicing carried out by an authorised MAKINEX dealer/service technician means that you cannot take advantage of the MAKINEX limited warranty.

MAKINEX warrants each new mixer to be free from defects in material and workmanship under normal domestic and industrial use and service for the period specified below, conditional to the limitations and exclusions printed on this page. This warranty applies only to new MAKINEX mixer distributed by us and by our authorised MAKINEX dealers.

Under the limited warranty and at MAKINEX's discretion, upon evaluation, inspection and testing by a MAKINEX dealer or a MAKINEX service technician, MAKINEX will repair and replace of defective part(s).

AUSTRALIA: Our goods come with guarantees that cannot be excluded under the Australian Consumer Law. You are entitled to a replacement or refund for a major failure and compensation for any other reasonably foreseeable loss or damage. You are also entitled to have the goods repaired or replaced if the goods fail to be of acceptable quality and the failure does not amount to a major failure.

### **WARRANTY: (Ex-factory/ Reseller premise)**

MAKINEX warrants to the original purchaser:

- MAKINEX provides a Limited One Year Warranty that applies to Jackhammer Trolley only (this excludes the Jackhammer and any other attachments and consumables).
- Any unauthorized repair or part replacement will void warranty. Refer to manufacturer for all repairs.
- Regular service must be carried out by competent persons only; failure to comply will void warranty.
- Jackhammer (where purchased) is to be covered by original manufacturer. Please refer to their manual for more information.

Transportation charges on product submitted for repair or replacement under this warranty are the sole responsibility of the purchaser. This warranty only applies to the original purchaser and is not transferable.

## **WARRANTY EXCLUSIONS**

---

- Warranty does not cover wear and tear, breakage, misuse or theft.
- Warranty does not cover consumables (e.g. blades).
- Warranty does not cover attachments (e.g. Shanks and Tile Smasher heads).
- Warranty will not apply to parts and/or labour if this Jackhammer Trolley is deemed to be misused, neglected, installed improperly or set up incorrectly.
- Cosmetic defects such as decals and coating.
- Failures due to acts of God and other force majeure events beyond the manufacturer's control.
- Problems caused by parts that are not original MAKINEX parts.
- Expedited freight costs.

## **OWNER'S RESPONSIBILITY UNDER THIS LIMITED WARRANTY**

---

Strict adherence to the maintenance checks and schedule with proof of scheduled maintenance service required by an authorised agent or qualified mechanic. It is the consumer's responsibility to deliver the machine in question to our service premises or to the premises of our appointed agent at the consumer's expense for replacement or repair as applicable. Maintenance services are not covered under warranty.

### **Claim Procedure:**

- Contact MAKINEX by phone or email informing us of your machines problem or defect.
- Once the extent of the claim has been assessed, we retain the right to compensate the consumer for such defect, or repair (parts & labour), or replace the machine under warranty.
- All warranties will be carried out by MAKINEX authorised staff or appointed agents at a premise to be determined by the Manufacturer.
- It is the responsibility (and cost) of MAKINEX or our appointed agent to return the machine to be repaired or replaced under warranty to the consumer- this is valid for domestic territories only (e.g. machine purchased in USA will repaired/replaced under warranty and returned to the USA consumer. Machine purchased in Australia will be repaired/ or replaced under warranty and returned to the Australian consumer etc.)
- Where the specific warranty component (e.g. Jackhammer) is under a Manufacturer's warranty other than MAKINEX (e.g. Bosch, Hitachi, Makita, Hilti etc), the consumer can either contact MAKINEX or the applicable Manufacturer for repairs where such warranty was registered with that manufacturer at purchase.
- Warranty calls will only be carried out by our representatives and not via client's choice of repairer. We will not accept back charges for any work not carried out by our representatives or accept any charges due to equipment being un-operational for any reason even during its warranty period.

## CONTACT INFORMATION

For sales, service, warranty and parts for all MAKINEX products; please refer below.

	<b>SALES, SERVICE, SPARE PARTS &amp; WARRANTY</b>
<b>AUSTRALIA</b>	<p style="text-align: center;"><b><u>SALES</u></b></p> <p style="text-align: center;">TEL 1300 795 953 or +61 2 9460 8071 WEB <a href="http://www.makinex.com.au">www.makinex.com.au</a></p> <p style="text-align: center;"><b><u>SERVICE, SPARE PARTS &amp; WARRANTY</u></b></p> <p style="text-align: center;">EMAIL <a href="mailto:service@makinex.com.au">service@makinex.com.au</a></p>
<b>USA</b>	<p style="text-align: center;"><b><u>SALES</u></b></p> <p style="text-align: center;">TEL +1 855-625-4639 WEB <a href="http://www.makinex.com">www.makinex.com</a></p> <p style="text-align: center;"><b><u>SERVICE, SPARE PARTS &amp; WARRANTY</u></b></p> <p style="text-align: center;">EMAIL <a href="mailto:service@makinex.com">service@makinex.com</a></p>
<b>UK</b>	<p style="text-align: center;">WEB <a href="http://www.makinex.co.uk">www.makinex.co.uk</a></p>
<b>EUROPE</b>	<p style="text-align: center;">TEL +31 (0)6 24881203 or +31 (0)6 50841849 EMAIL <a href="mailto:info@mttools.eu">info@mttools.eu</a></p>
<b>CHINA</b>	<p style="text-align: center;">TEL +86 18951118278 EMAIL <a href="mailto:sales@makinex.com.cn">sales@makinex.com.cn</a></p>

**Or your nearest MAKINEX distributor**

We have very knowledgeable, experienced staff to assist you with help and advice.



# APPENDICES

- A. BLOCK SETS BREAKDOWN
- B. JACKHAMMER TROLLEY - HAZARD ASSESSMENT

## APPENDIX A – UNIVERSAL BLOCK SET BREAKDOWN

ITEM NO.	/PART NO.	/DESCRIPTION	/QTY.
1	JHT-09-21	B3 ADAPTOR	2
2	JHT-09-02	CUTOFF TOP PLATE	1
3	JHT-09-11-1	B-BLOCK	2
4	JHT-09-12	F-BLOCK	2
5	JHT-09-13	B1-ADAPTOR	2
6	MAK-UP-541	M10 X 250 HEX HEAD BOLT	4
7	MAK-UP-543	M10 HEXNUT NYLOC	6
8	MAK-UP-542	M10 PLAIN FLAT WASHER	6
9	JHT-09-14	B2 ADAPTOR	2
10	JHT-09-15	F1 ADAPTOR	2
11	JHT-09-W-1	HILTI HANDLE WELDMENT	1
12	JHT-09-22	TOP HANDLE PLATE	1
13	MAK-UP-545	M10X65 HEX BOLT	2
14	JHT-09-19	P CLIP 10mm	1
15	JHT-09-17-1	HILTI HANDLE MOUNT LOWER	1
16	JHT-09-16-1	HILTI HANDLE MOUNT UPPER	1
17	MAK-UP-544	M8 X 80 HEX BOLT	2
18	MAK-UP-511	M8 HEXNUT NYLOC	2
19	JHT-09-06	HILTI F BLOCK TOP PLATE	1
20	MAK-UP-613	M10 X 270 HEX HEAD BOLT	2

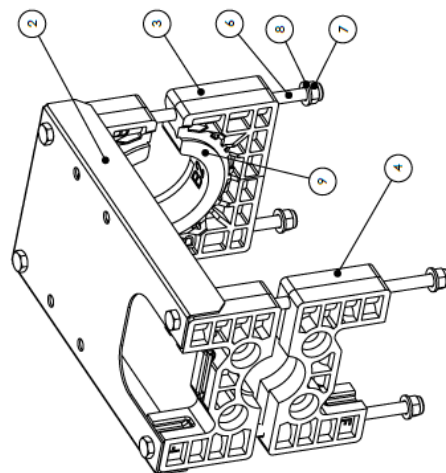

PRINT MAY BE REDUCED - DO NOT SCALE

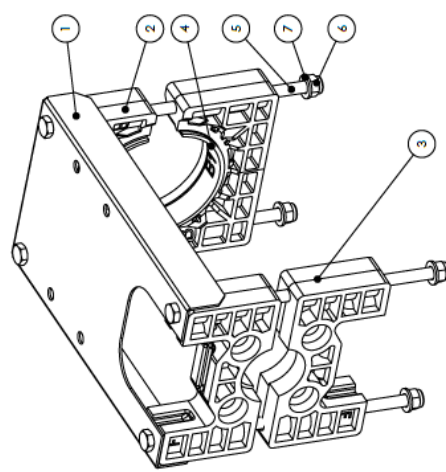

HITACHI/HIKOKI & DEWALT CLAMP ASSEMBLY

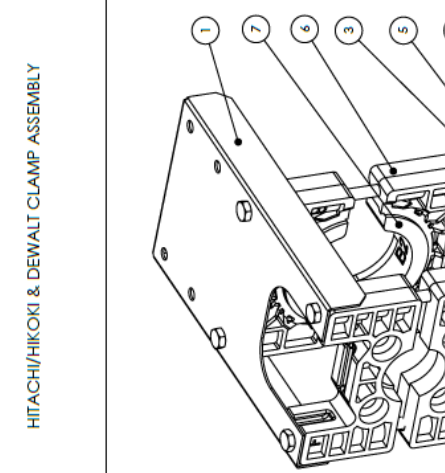

BOSCH CLAMP ASSEMBLY

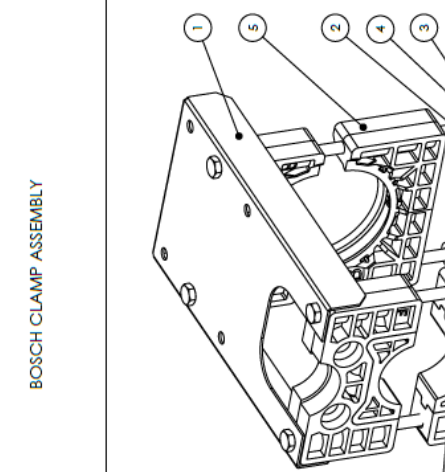

MILWAUKEE CLAMP ASSEMBLY

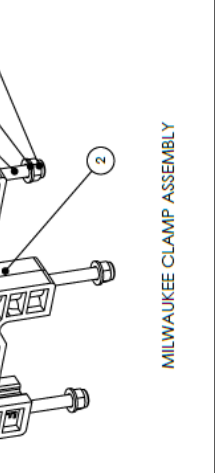

MAKITA CLAMP ASSEMBLY

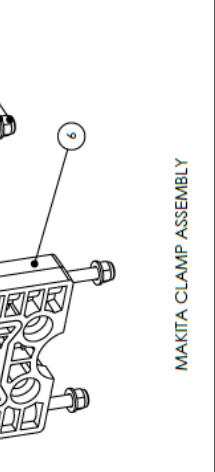

HILTI CLAMP ASSEMBLY



www.makinex.com



# APPENDIX B – JHT-U-2 RISK ASSESSMENT

## PRODUCT RISK / HAZARD ASSESSMENT TABLE

PRODUCT NAME:	JHT-U-2	Assessment Carried Out By:	JOSHUA THAI
MANUFACTURER:	MAKINEX	Document Revision Number:	004
OPERATOR COMPETENCY:	PLANT LICENCE NOT REQUIRED	Date Created:	25/10/2018

No:	TYPE / NATURE OF RISK OR HAZARD	LIKELIHOOD	CONSEQUENCE		RISK LEVEL	CONTROL ACTION			
1.0	MECHANICAL HAZARD	1.1	PINCHING/CRUSHING – INADVERTNAT PLACEMENT OF FINGERS IN PIVOT POINT	2	2	3	MINOR	MEDIUM	- SAFE OPERATION OF LOWERING MECHANISM
		1.2	STABBING/PUNCTURE – FROM BLADE/MOIL DURING OPERATION, INSTALLATION OR REMOVAL	3	3	3	MINOR	MEDIUM	- ALWAYS WEAR APPROPRIATE PROTECTIVE GLOVES
		1.3	CRUSHING – DROPPING THE MACHINE WHILST LIFTING.	2	3	3	MINOR	MEDIUM	- USE HOIST OR TWO PEOPLE TO LIFT MACHINE
		1.4	CRUSHING – DROPPING HAMMER WHILE UNINSTALLING FROM TROLLEY	2	3	3	MINOR	MEDIUM	- ALWAYS WEAR APPROPRIATE PROTECTIVE FOOTWARE
2.0	ELECTRICAL HAZARD	2.1	ELETRIC SHOCK – SEVERING LEADS	2	2	1	FATALITY	HIGH	- WIRES COATED, PROTECTED AND SECURED - HANDLES INSULATED
3.0	HAZARD BY NOISE	3.1	DEAFNESS (LONG TERM USE)	4	2	2	MAJOR	MEDIUM	- ALWAYS WEAR HEARING PROTECTIONS
4.0	HAZARD BY VIBRATION	4.1	STRAIN	3	3	2	MINOR	MEDIUM	- 3 POINTS OF VIBRATION ABSORPTION
5.0	HAZARD BY MATERIAL AND SUBSTANCES	5.1	IRRITATION – TO SKIN DUE TO MATERIALS USED	4	3	3	MINOR	LOW	- WEAR APPROPRIATE LONG-SLEEVED EQUIPMENT - AVOID THE USE OF HAZARDOUS MATERIALS
		5.2	INHALATION – MINOR DEBRIS PARTICLES	1	2	1	MAJOR	HIGH	- ALWAYS WEAR APPROPRIATE PROTECTIVE MASK
		5.3	IMPACT – BROKEN DOWN PARTICLES FLYING INTO THE EYES	2	3	2	MINOR	MEDIUM	- ALWAYS WEAR APPROPRIATE PROTECTIVE GOGGLES - ALWAYS WEAR APPROPRIATE PROTECTIVE MASK
6.0	HAZARD DUE TO POOR EGONOMICS	6.1	BACK INJURY – BENDING WHILST ADJUSTING BLADE POSITION	3	2	2	MAJOR	MEDIUM	- SAFE OPERATION OF LEVER
		6.2	BACK INJURY – LIFTING THE MACHINE	2	3	2	MINOR	MEDIUM	- TRAINING STAFF TO LIFT WITH THE LEGS - USE HOIST OR TWO PEOPLE TO LIFT MACHINE

**NOTES:**

- > THIS PRODUCT HAS BEEN DESIGNED AND MANUFACTURED AS A GENERATOR ONLY
- > THIS DOCUMENT HAS BEEN PREPARED ACCORDING TO GUIDELINES AND RECOMMENDATIONS FOUND IN:
  1. 'HAZPAK' PRODUCED BY THE WORK-COVER AUTHORITY AND
  2. THE AUSTRALIAN STANDARDS 4024.1.4/5 -1996
- "SAFEGUARDING OF MACHINERY - PART 1: GENERAL PRINCIPLES-AUSTRALIAN STANDARD, AS/NZS 3760:IN-SERVICE SAFETY INSPECTION AND TESTING OF ELECTRICAL EQUIPMENT.

"LIKELIHOOD LEVEL" REFERS TO THE PROBABILITY OF AN EVENT HAPPENING. THE FOLLOWING SCALE HAS BEEN USED TO DESCRIBE THE LIKELIHOOD OF A DEFINED RISK / HAZARD EVENT OCCURRING DURING NORMAL OPERATION OF THE EQUIPMENT. NOTE THAT LIKELIHOOD EVALUATION IS QUALITATIVE AND BASED ON BEST ESTIMATION VIA CONSULTATION AND EXPERIENCE:

1. VERY LIKELY
2. LIKELY
3. UNLIKELY
4. VERY UNLIKELY

"CONSEQUENCE" REFERS TO THE SEVERITY OF INJURY CAUSED DUE TO AN EVENT OCCURRING, USING THE FOLLOWING SCALE AS DEFINED BY THE "HAZPAK" DOCUMENT:

1. FATALITY = INJURIES RESULT IN DEATH
2. MAJOR = NORMALLY IRREVERSIBLE INJURIES
3. MINOR = REVERSIBLE INJURIES REQUIRING SEVERAL DAYS OFF
4. NEGLIGIBLE = ABLE TO BE TREATED USING FIRST AID

"RISK LEVEL" REFERS TO THE SEVERITY OF A RISK BASED ON THE "LIKELIHOOD LEVEL" AND "INJURY LEVEL". INHERENTLY, AS THE CONSEQUENCE INCREASES IN SEVERITY, RISK INCREASES - EVEN WHEN LIKELIHOOD IS LOW - THE FOLLOWING SCALE HAS BEEN USED:

1. HIGH = POTENTIAL DEATH, PERMANENT DISABILITY, OR MAJOR STRUCTURAL DAMAGE.
2. MEDIUM = POTENTIAL TEMPORARY, DISABILITY, OR MINOR STRUCTURAL DAMAGE.
3. LOW = POTENTIAL INCIDENT THAT HAS THE POTENTIAL TO CAUSE PERSONS TO REQUIRE FIRST AID.

